



## Forged Steel Gate Valves 1/2" - 2" Bolted Bonnet

*Gate Valves ANSI/API Class 150-800: our bellows technology keeps corrosive or harmful atmospheric conditions from entering the process.*



*interior cut-away*

### Applications:

- For use in applications where leakage into or out of the valve is unacceptable such as heat transfer oil, toxic fluids, steam and regulated media.

### Features:

- Inconel™ bellows provides longer life and maximum corrosion resistance
- very compact, lower piping costs
- zero stem leakage eliminates media loss and satisfies environmental regulations
- zero maintenance results in lower operating costs / no downtime
- reduce monitoring costs
- three stem seals for safety: metallic bellows, graphite packing, backseat in open position
- hardfaced Stellite® 6 seating surface provides long life
- additional alloys, trims and other end configurations available

### Standards:

- valve tested to ASME B16.34 / API 598
- meets MSS SP-117
- 5 year bellows warranty

## Dixon Eagle

33 Plan Way - Building 5 • Warwick, RI 02886  
ph 401.732.0333 • toll free 800.314.9246 • fx 401.732.2201  
eaglesales@dixonvalve.com  
dixonvalve.com

# Bellows Seal Valves

W8

## Materials

No.	Description	Carbon Steel (C22)	316L Steel (S44)
1	body	A105	A182 F316L
2	seat ring	type 316 stainless <sup>1</sup>	type 316 stainless <sup>1</sup>
3	bonnet	A105	A182 F316L
4	gate	type 420 stainless	type 316 stainless <sup>1</sup>
5	bellows assy.	Inconel™ 625 <sup>2</sup>	Inconel™ 625 <sup>2</sup>
6	stem	type 410 stainless	type 316 stainless
7	joint bolt	A193 B7	A193 B8
8	gasket	graphite / 316 SS	graphite / 316 SS
9	gland packing	graphite	graphite
10	gland bushing	type 410 stainless	type 304 stainless
11	gland plate	carbon steel	type 316 stainless
12	gland bolt	type 410 stainless	type 304 stainless
13	pin	type 410 stainless	type 304 stainless
14	hex nut	carbon steel	type 304 stainless
15	yoke sleeve	type 410 stainless	copper alloy
16	thrust collar	type 410 stainless	type 410 stainless
17	handwheel	malleable iron	malleable iron
18	handle nut	carbon steel	type 304 stainless
19	grease fitting	copper alloy	copper alloy
20	name plate	aluminum	aluminum

<sup>1</sup> Stellite™ overlay on seating area. Stellite™ is a registered trademark of Thermadyne.

<sup>2</sup> Inconel™ is a trademark of Huntington Alloys, Inc.

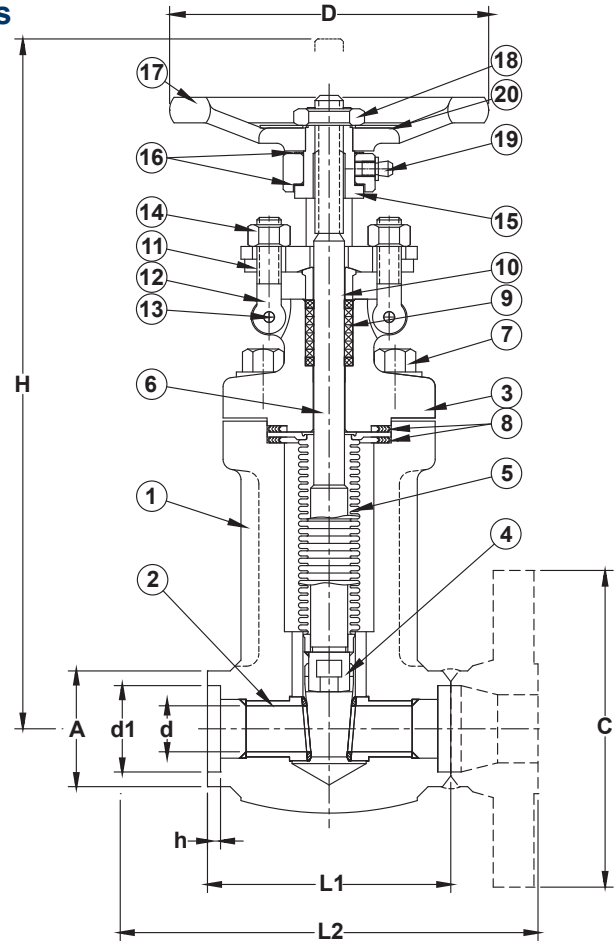

## Operating Characteristics and Dimensions Socket Weld / Threaded Gate Valves

Size	d	A	d1	h	L1	H	D	LIFT	Wt (lbs)	Cv
½	.39	1.34	.855	.39	3.11	9.3	3.94	.51	7	7.1
¾	.54	1.57	1.065	.51	3.62	10.1	3.94	.67	8	15.0
1	.71	1.93	1.330	.51	4.37	12.2	4.92	.87	14	25.0
1½	1.14	2.56	1.915	.51	4.72	16.0	6.30	1.34	25	75.0
2	1.45	3.07	2.406	.63	5.51	18.6	7.09	1.69	40	120.0

## Flanged Gate Valves

Size	150			300			600		
	L2	C	Wt (lbs)	L2	C	Wt (lbs)	L2	C	Wt (lbs)
½	4.25	3.50	10	5.50	3.75	12	6.50	3.75	13
¾	4.62	3.88	12	6.00	4.62	16	7.50	4.62	17
1	5.00	4.25	18	6.50	4.88	22	8.50	4.88	24
1½	6.50	5.00	31	7.50	6.12	39	9.50	6.12	41
2	7.00	6.00	50	8.50	6.50	58	11.50	6.50	61

## Warning & Safety



Dixon Eagle valves are designed to work safely for their intended use. Failure to know and understand the intended use or to consider the size, temperature, application, media, pressure and manufacturers recommendations when selecting the proper valve assembly components can result in accidents and injuries, including death and serious and permanent injuries. Dixon recommends that all valve assemblies be tested in accordance with ASME and API recommendations and be inspected regularly to ensure that their use remains appropriate and that they are not damaged.

At no charge, Dixon is available to consult, train and recommend the proper selection and application of all valves we sell. We strongly recommend that distributors and end users make use of Dixon's Testing and Recommendation Services. Call 800.355.1991 to learn more.

ph 401.732.0333 • toll free 800.314.9246 • fx 401.732.2201  
 eaglesales@dixonvalve.com  
 dixonvalve.com