

Dixon Specialty Products

Loading Arm

Manual



The Right Connection®

Dixon Specialty Products

225 Talbot Blvd. • Chestertown, MD 21620

ph: 888.226.4673 • fx: 410.778.1958

dixonvalve.com

Introduction

This manual contains an order guide, installation and operating instructions, maintenance, trouble shooting and safety notes for the Dixon Specialty Products Loading arm. Please read and understand this manual prior to installing, operating or servicing this product.

Table of Contents

How To Order Guide	3 - 5
Installation Instructions	6
Operating Instructions	7 - 9
Loading Arm Maintenance.....	10 - 13
Trouble Shooting	14
Safety	14
Limited Warranty	15

How To Order Guide

1. Counterbalance part number sequence

Part Number	Orientation	Spring Color	Load capacity ¹
ESB1-A	Right-hand	White	Light-weight
ESB1-B	Right-hand	Yellow	Medium-weight
ESB1-C	Right-hand	Red	Heavy-weight
ESB1-E	Left-hand	Black	Light-weight
ESB1-F	Left-hand	Gray	Medium-weight
ESB1-G	Left-hand	Orange	Heavy-weight

¹ Contact Dixon® for appropriate spring based on individual application.

2. Common Accessories: (Many others available upon request such as: deadman style valves and ball-style handles.)



D-handle



Breakaway

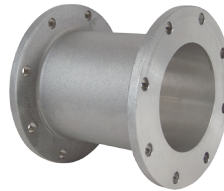

Flange extension



Sight glass



Cam & groove



API



Deflectors

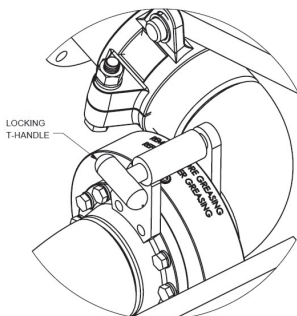

DETAIL B

Split-flange swivel locking devices (single hole location)

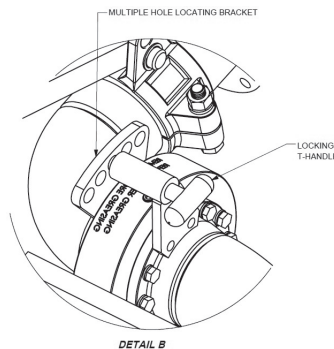
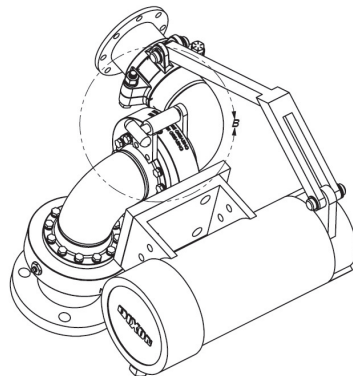

DETAIL B

Split-flange swivel locking devices (multiple hole locations)

Note: Dixon® offers a full engineering team to design and develop any product or new idea. We offer loading arms as either new turn-key systems or replacement parts for any loading arm application.

How To Order Guide, cont.

3. Configuration(s)

a.
A-frame

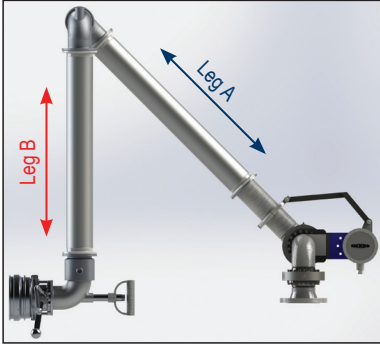

b.
Upfeed

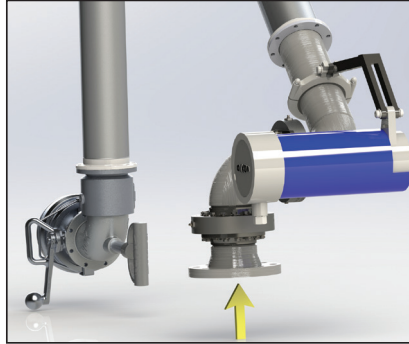

c.
Left-hand

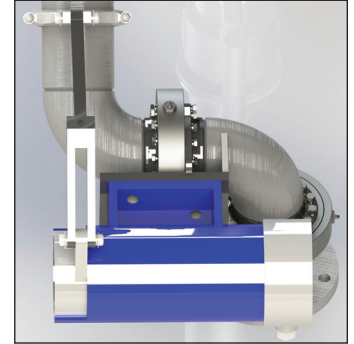

Horizontal (top load)

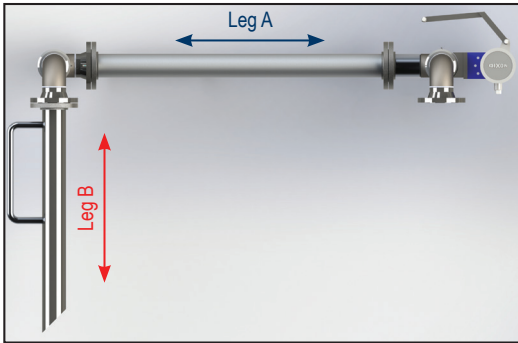

Downfeed

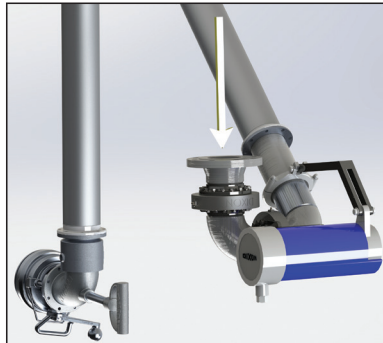

Right-hand

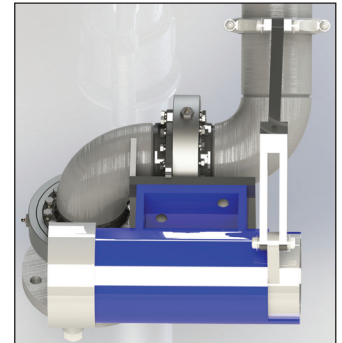

d.
Other style arm: _____

4. Component Measurements and Material (measure from center of swivel to center of swivel to the whole foot, i.e. 48", 60", etc.)

Leg A
Length: _____ **Material:** carbon steel aluminum stainless steel

Leg B
Length: _____ **Material:** carbon steel aluminum metal hose stainless steel
 composite hose

How To Order Guide, cont.

5. Application Information

- a. End User: _____ Contact Name: _____ Number: _____ Email: _____
 Distributor: _____ Contact Name: _____ Number: _____ Email: _____
- b. Quantity: _____
- c. Pipe size: 2" 3" 4" Misc. _____"
- d. Base swivel: Split flange style V-ring style O-ring style
- e. Riser stand pipe connection: 150 ANSI flange 300 ANSI flange TTMA flange Other: _____
- f. Type of media: Asphalt Fuel Other media _____
- g. Terminal end connections (optional items for each media):
- | | | | |
|---------------------------------------|--------------------------------------|--------------------------------------------|--------------------------------------|
| <input type="checkbox"/> 45° pipe cut | <input type="checkbox"/> bucket hook | <input type="checkbox"/> deflector | <input type="checkbox"/> handle |
| <input type="checkbox"/> API coupler | <input type="checkbox"/> breakaway | <input type="checkbox"/> flange extension | <input type="checkbox"/> sight glass |
| <input type="checkbox"/> D handle | <input type="checkbox"/> ball handle | <input type="checkbox"/> locking mechanism | |
- h. Seals (Dixon can recommend based on media): Buna-N Viton™ PTFE FKM A&B EPDM

6. Site Limitations:

- a. Ceiling or roof height from riser pipe connection distance:

- b. Additional items (vapor hoses, drip buckets, hold-down chains etc. and estimated weight (pounds):

- c. Range of motion required (list approximate range of motion desired by clock method or degree method):

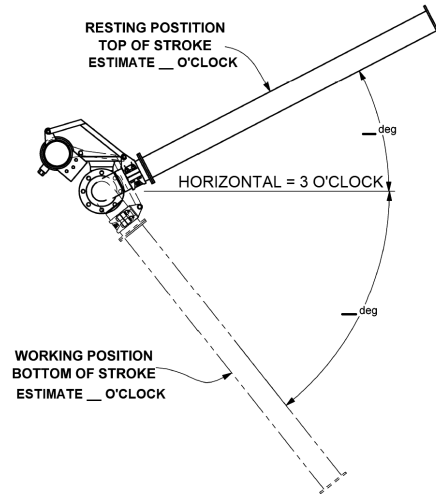

7. Sketches / Notes:

Installation Instructions

1. Wear Personal Protective Equipment (PPE). When performing maintenance or working on the Loading arm always wear adequate personal protection, including hard hats, gloves, safety glasses and steel-toed work boots.

2. Lift using appropriately rated straps using the shown possible attachment points.



3. Bolt torque chart and tighten sequence (use appropriate gaskets and bolts)

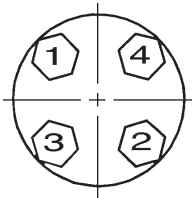

4 Bolt

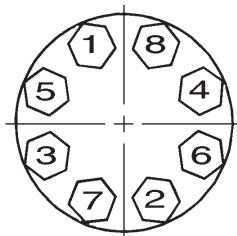

8 Bolt

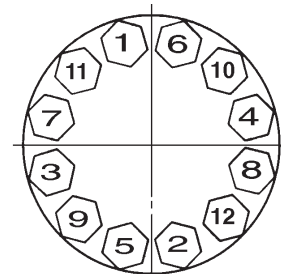

12 Bolt

- a. TTMA flange bolt(s) = 25 Ft.lbs. (tank truck flange)
- b. 150 Pound Flange bolt(s) = 32 Ft.lbs.
- c. Counterbalance clamp bolt(s) 30 Ft.lbs.

4. Prior to installing the loading arm on an existing riser pipe flange, inspection of the riser piping and connection flange should be conducted. Ensure that the inlet is leveled and plumb which will prevent the loading arm from rotational drift. Also, confirm the flange sealing surface is not damaged to prevent leaks.

5. The entire loading arm should be assembled on the ground in a horizontal position and then raised to the inlet piping flange as a complete overall unit. Most of our assemblies will be shipped completely assembled. Be sure to align all flange gaskets properly in between the flanges and tighten connections per the Bolt tightening sequence diagram.

6. Once installed, adjust the spring tension per the spring adjustment section and position the upward/downward travel stop(s). Reference Operating Instructions on pages 7 - 9.

Operating Instructions

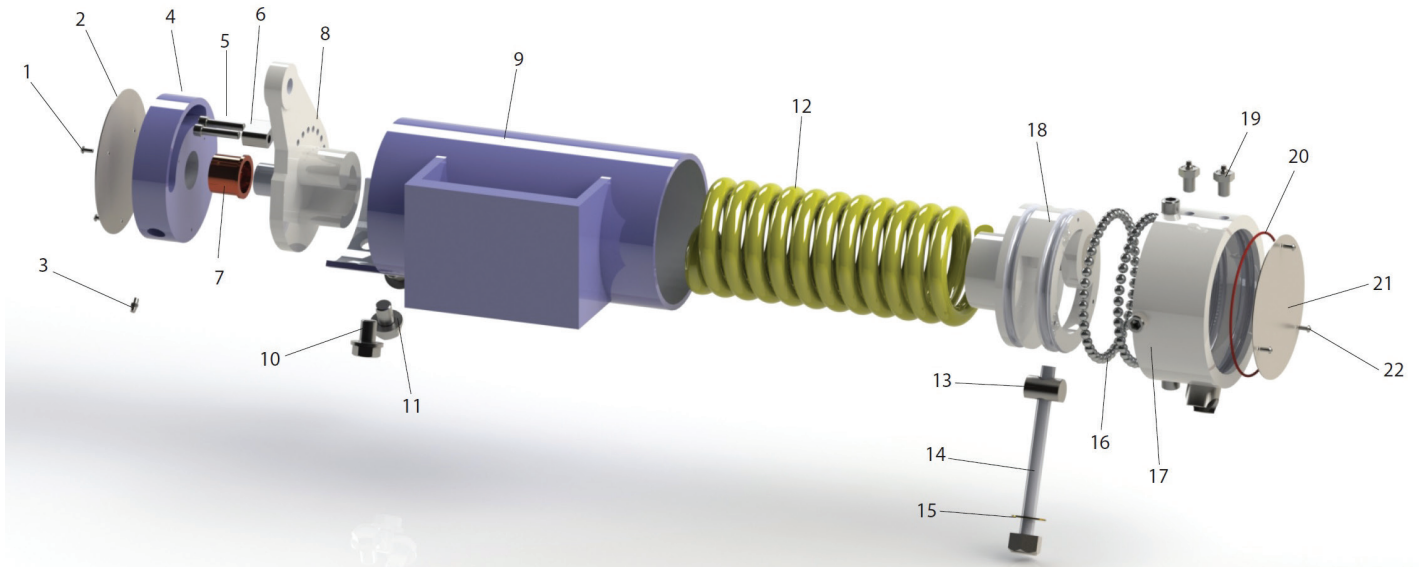

Item	Qty	Part Number	Description
1	3	AT1321	Button head stainless steel Allen screw - metric 4
2	1	AT1299	Stainless steel name plate
3	1	AT1320	Stainless steel grease fitting
4	1	AT1264	Carbon steel side mounting
5	2	AT1302	Socket head stainless steel Allen screw - $\frac{5}{16}$ " x $1\frac{1}{2}$ "
6	1	AT1301	Stainless steel travel stop
7	1	AT1325	Brass bushing
8	1	AT1326	Ductile iron actuator
9	1	AT1255	Carbon steel main body
10	3	AT1318	Stainless steel hexagonal head bolt $\frac{5}{8}$ "-11 x $1\frac{1}{2}$ "
11	3	AT1319	Stainless steel grower washer $\frac{5}{8}$ "
12	1	AT1324	Torsion spring
13	1	AT1258	Stainless steel cylindrical washer
14	1	AT1262	Adjustment bolt
15	1	AT1327	Brass washer $\frac{5}{8}$ "
16	84	AT1328	Ball bearings $\frac{3}{8}$ "
17	1	AT1256	Carbon steel female raceways body
18	1	AT1257	Carbon steel male raceways adjusting device
19	2	AT1296	Stainless steel grease fitting cups
20	1	AT1329	Environmental seal
21	1	AT1300	Stainless steel plate
22	3	AT1321	Button head stainless steel Allen screw - metric 4

Operating Instructions, cont.

Counterbalance adjustment and balancing. The loading arm is balanced and adjusted at the factory for all complete arm packages but may need minor fine tuning once installed on-site due to weight of media, shipping vibrations etc.

1. Spring adjustment:

a. Prior to any work, reference the Safety section on page 14. Wear Personal Protective Equipment (PPE) during the installation.

- Remove Dixon® cover on the side with the pivot arm (item 2).
- Remove the mechanical stop secured with two hex bolts (items 5 and 6).

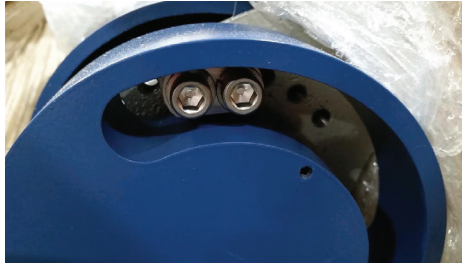

- Remove tension from the spring by lifting the arm up. Lift the loading arm to highest possible position to unload spring tension and secure the arm.



- Once tension is removed, make small ½ turn increments to the adjustment bolt (item 14). Use caution when releasing the arm. Allow the arm to 'settle' into a natural position before determining whether or not further adjustment is required.
 - Tightening increases spring torque/loosening decreases spring torque.



Operating Instructions, cont.

2. Spring wear (removal and replacement)

- a. As the spring is used over time, the spring wears until the spring has reached the end of its service life:
 - To change the spring out, all tension must be removed from the spring and the pivot arm bar must be removed.

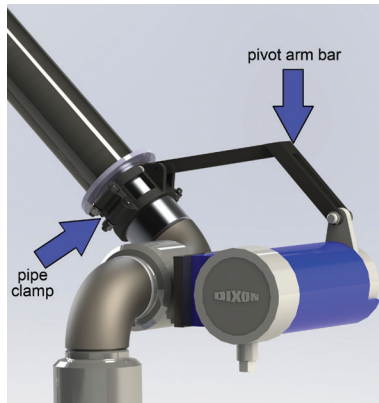

- Remove 3 bolts on the pivot arm side of the counterbalance (Item 10).
- Pull the carbon steel side mount end plate (item 4) and associated parts of the housing.
- Remove the spring (item 12) and replace.
- Reinstall in the reverse order.

3. Effects of pipe clamp movement:

- a. As the clamp is moved further out on the arm the result will be less felt weight at the terminal end and if the clamp is moved closer to the pivot location the more felt weight will result.
- b. Clamp bolts should be tightened in a crisscross pattern to 30 ft lbs. and checked during a regular maintenance schedule.

Loading Arm Maintenance

Reference the following information to assist in general maintenance and seal replacement for all Dixon Specialty Products swivel joints. Take all necessary safety precautions when assembling and operating these units. Handle all components with cleanliness and care.

1. Lubrication (grease fittings)

- a. Grease schedule: Lubrication should be performed on a regularly scheduled basis (e.g. bi-annually, quarterly or monthly), depending on service and operating conditions.
- b. Inject grease and rotate the unit as it is applied to ensure an even application throughout the raceway. Do not over-lubricate, as this may displace the seals and result in leakage. Use a manual grease gun in order to feel pressure inside the swivel, if you feel the pressure is high the swivel may be over greased and one of the ball plugs should be removed for a visual inspection. Periodically remove both ball plugs in order to visually inspect the ball race and one or two of the ball bearings. If there is material inside this cavity the pressure seal has been compromised resulting in a leak and the swivel should be rebuilt. If you find metal in the grease or have any concerns about the shape of the ball bearings or races please contact us immediately as this could be signs of excessive wear.
- c. Grease points: all swivel joints are supplied with a grease fitting at each plane of rotation. Special note about the split flange style swivel: remove the "grease inspection port" prior to greasing(see page 13).
- d. Type of grease: all swivels are filled with Renolit Replex 2 grease at the factory with NLGI Grade 2. Some applications may require different grease available upon request.

2. Re-torque bolts (clamps, counterbalance bolts, flanges etc.) and ensure the E-clips are in place on the counterbalance pivot bar (e.g. bi-annually, quarterly or monthly), depending on service and operating conditions. We recommend using a thread lock sealant or lock washers to prevent any loosening due to vibration (Loctite Blue).

3. We recommend a spring adjustment on the counterbalance after the first 2 months in service depending on use to account for initial spring wear. (see spring adjustment section in this manual)

4. All swivels are designed to be rebuildable once they have reached the end of their service life, refer to pages 11 - 13 for swivel seal replacement procedures.

Loading Arm Maintenance, cont.

Swivel work instructions for replacing **O-ring swivel seals**.

Note: Instructions are not for assembly with spring-loaded PTFE pressure seal, consult Dixon®.

1 Remove the ball retainer screws. Add a sufficient amount of solvent into each raceway to flush out the lubricant. Rotate the sleeve, catching the balls as they fall out. When all the balls have been removed, the body and sleeve can be separated. Discard old seals. Thoroughly clean the body and sleeve.

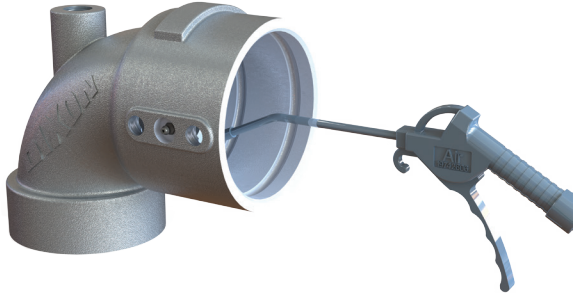

4 Insert the sleeve into the body, slowly rotate the sleeve while inserting into the body.

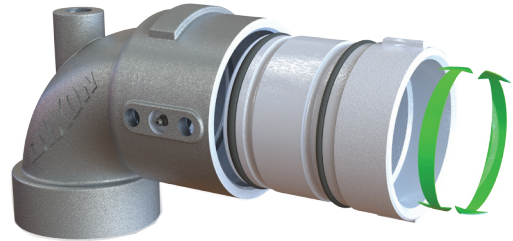

2 Install the new O-rings on the sleeve, dust seal to the rear, product (pressure) seal up front.

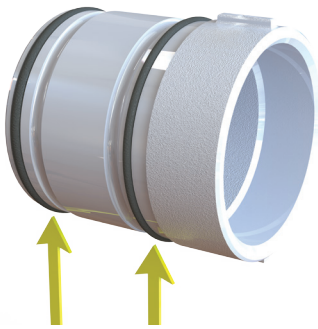

5 When the sleeve is fully inserted, feed the ball bearings into the raceways while rotating the sleeve. To make space for all the balls, insert a screw driver into the raceway, while continuing to rotate the sleeve in one direction (be careful not to damage the threads). This will cause the balls to jam up, making room for the remaining balls. Now reverse rotation of sleeve and insert the remaining balls.

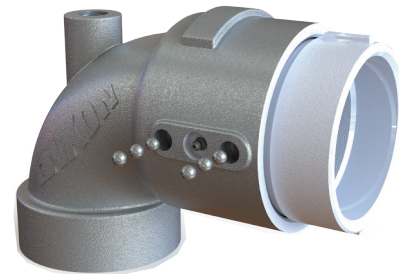

3 Lubricate the body and the sleeve with grease.

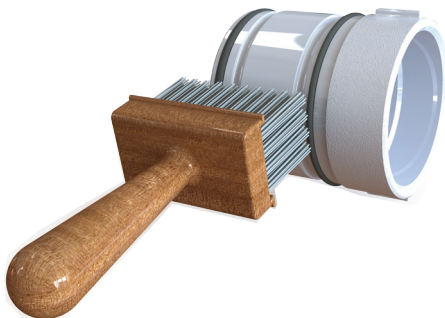

6 Reinstall ball retainer screws until tight. If this interferes with the smooth rotation of the ball bearings, then back off 1/8 - 1/4 turn. A thread locking sealant is recommended to prevent screws from backing off. After pressure testing, the unit is ready for installation.

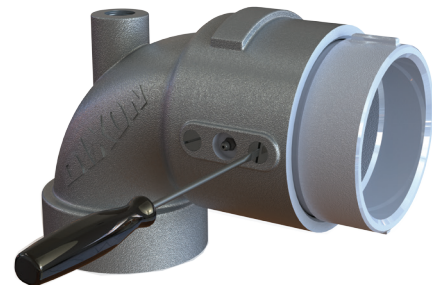

Body and sleeve are matched during manufacturing. Do not mix components with other units.

Loading Arm Maintenance, cont.

Swivel work instructions for replacing V-ring swivel seals.

1 Remove the ball retainer screws. Add a sufficient amount of solvent into each raceway to flush out the lubricant. Rotate the sleeve, catching the balls as they fall out. When all the balls have been removed, the body and sleeve can be separated. Discard old seals. Thoroughly clean the body, sleeve retainer, spring retainer and springs. ¹



2 Lubricate the body unit with a moly lubricant or equivalent.



3 Place the assembled spring retainer unit (spring end first) into the body. Place the set of V-rings onto the spring retainer. Be sure V-rings are installed with the sealing lips facing toward the retainer. Lubricate the body and seals with a Moly lubricant or equivalent.

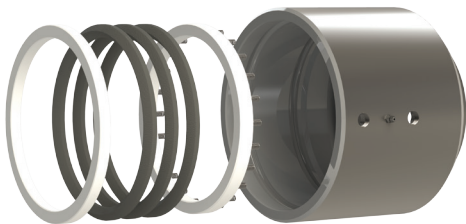

4 Set the dust seal into O-ring groove on the sleeve. Place the seal retainer on the sleeve with the grooved end facing the V-rings. Lubricate the sleeve with grease.

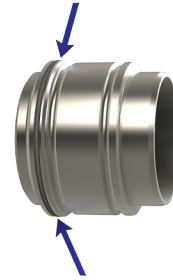

5 Insert sleeve into body, compressing swivel joint together until ball races of body and sleeve are in alignment (do not rotate either unit while compressing). Care should be taken to avoid pinching or scoring of V rings. Drop balls into raceway holes, rotating the sleeve slowly as you load. To make space for all the balls, insert a screw driver into the raceway while continuing to rotate the sleeve in one direction (be careful not to damage the threads). This will cause the balls to jam up, making room for the remaining balls. Now reverse the rotation of the sleeve and insert the remaining balls.

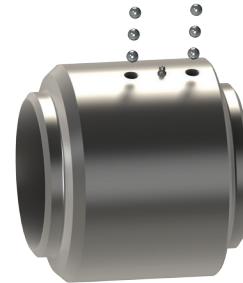

6 Reinstall ball retainer screws until tight. If this interferes with the smooth rotation of the ball bearings, then back off $\frac{1}{8}$ - $\frac{1}{4}$ turn. A thread locking sealant is recommended to prevent screws from backing off. After pressure testing, the unit is ready for installation.

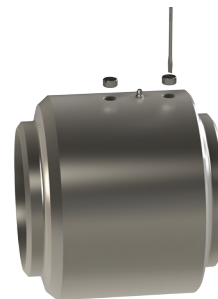

¹ The last coil of the springs has been upset (OD slightly larger). When upset end is inserted into the holes provided in the spring retainer, the springs remain secure.



Body and sleeve are matched during manufacturing. Do not mix components with other units.

Loading Arm Maintenance, cont.

Swivel work instructions for replacing **Split flange swivel seals**.

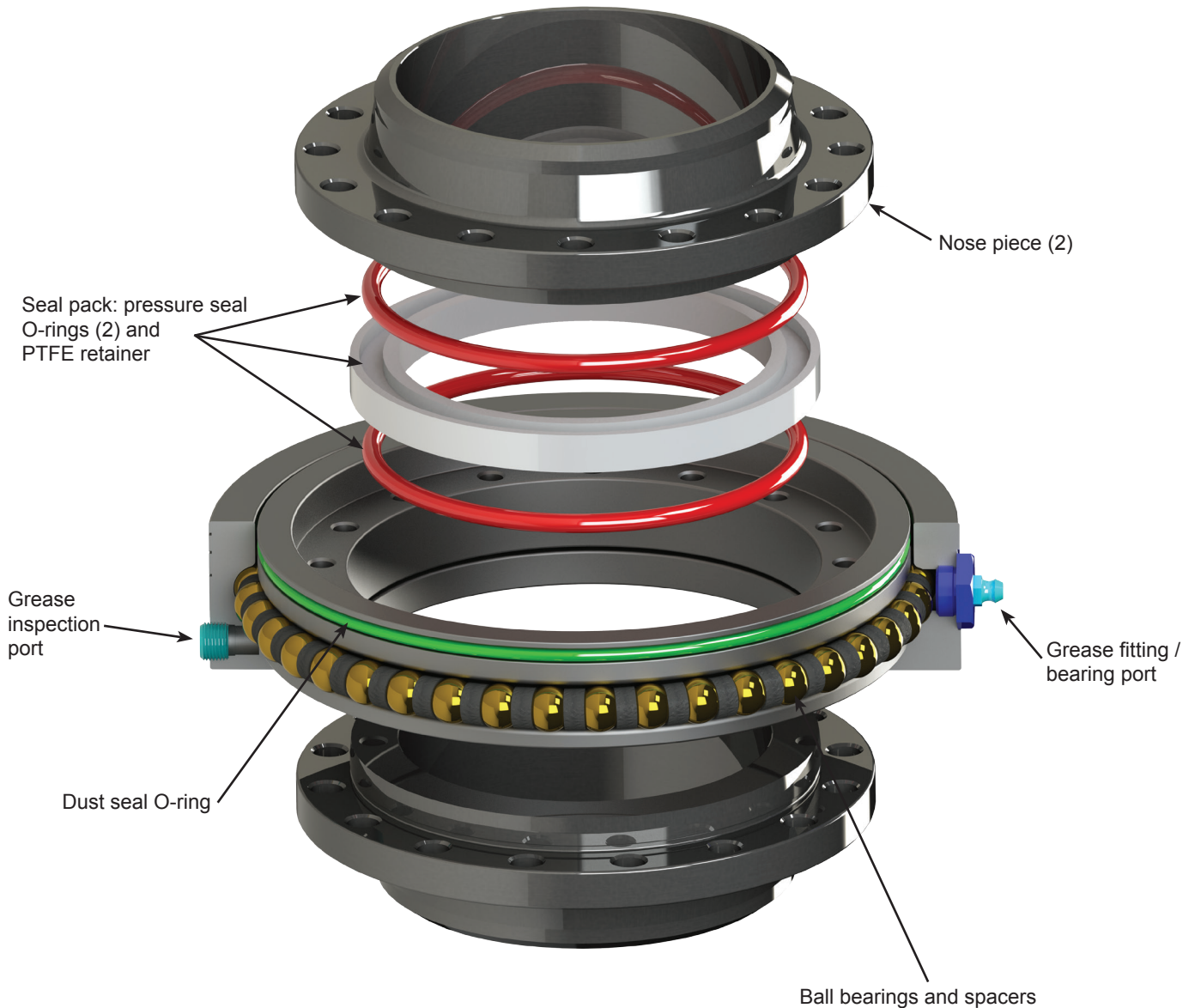

Instructions to replace the seal pack:

1. Remove the bolts connecting the nose piece on only one side of the swivel body (bearing pack).
2. Pull out the seal pack and install the new seals (ensure the o-rings are in the groove of the PTFE retainer).
3. Reinstall the bolts and torque in an alternating star pattern to 25 ft. lbs.

Trouble Shooting

Problem	Solution
Loading arm becomes un-balanced	Check clamp placement (ensure the clamp did not slide). Re-adjust and torque bolts
	Use adjustment nut as describe previously to re-adjust spring tension
	Consult Dixon® for further information
Swivel leaking	Re-torque flange bolts
	Grease per the loading arm service section on pages 10 - 13.
	Replace seals
API coupler leaking	Visit dixonvalve.com for information on rebuilding, maintenance and operating.
Loading Arm adjustment limited by obstructions (ceiling height, pipings, etc.)	Remove all the spring tension and turn the adjustment bolt using a standard wrench. Never use a cheater or breaker bar: The entire Loading Arm should be removed from the inlet stand pipe connection, brought to the ground, adjusted, and then re-installed. To avoid this step, use a shorter inlet stand pipe.

Safety

All counterbalances are shipped with the following label:

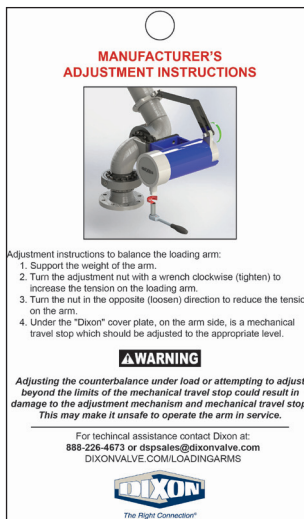

DANGER! Be aware of several pinch points around moving loading arms.

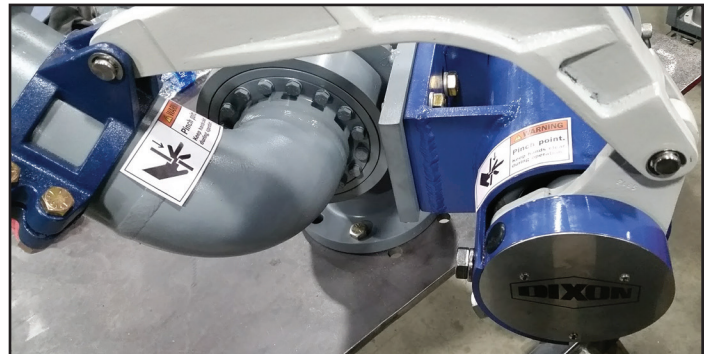

DANGER! Prior to any maintenance, secure the Loading Arm and remove tension from the spring inside the counterbalance housing. The Loading Arm utilizes a torsion spring which contains a substantial amount of tension. Tension must be dissipated prior to any disassembly. Failure to remove all tension from the spring may cause serious injury.



Warning: Never exceed the rated working pressure of the unit. Never modify or alter a unit beyond that to which it has been designed. Should any unit appear damaged, remove it from service immediately and contact Dixon®.



CAUTION: Loading arms are not provided with a pressure relief valve. Temperature variations and thermal expansion of liquid media can cause increased internal pressure. Therefore a pressure relief valve prior to the inlet connection point is required. Failure to install a relief valve prior to the loading arm may damage the equipment and cause injury.

Users must consider the size, temperature, application, media, pressure and hose and coupling manufacturer's recommendations when selecting the proper hose assembly components. Dixon® recommends that all hose assemblies be tested in accordance with the Rubber Manufacturers Association's recommendations and be inspected regularly (before each use) to ensure that they are not damaged or have become loose. Visit RMA.org for more information.

Limited Warranty

DIXON VALVE AND COUPLING COMPANY (herein called "Dixon") warrants the products described herein, and manufactured by Dixon to be free from defects in material and workmanship for a period of one (1) year from date of shipment by Dixon under normal use and service. It's sole obligation under this warranty being limited to repairing or replacing, as hereinafter provided, at its option any product found to Dixon's satisfaction to be defective upon examination by it, provided that such product shall be returned for inspection to Dixon's factory within three (3) months after discovery of the defect. The repair or replacement of defective products will be made without charge for parts or labor. This warranty shall not apply to: (a) parts or products not manufactured by Dixon, the warranty of such items being limited to the actual warranty extended to Dixon by its supplier; (b) any product that has been subject to abuse, negligence, accident, or misapplication; (c) any product altered or repaired by others than Dixon; and (d) to normal maintenance services and the replacement of service items (such as washers, gaskets and lubricants) made in connection with such services. To the extent permitted by law, this limited warranty shall extend only to the buyer and any other person reasonably expected to use or consume the goods who is injured in person by any breach of the warranty. No action may be brought against Dixon for an alleged breach of warranty unless such action is instituted within one (1) year from the date the cause of action accrues. This limited warranty shall be construed and enforced to the fullest extent allowable by applicable law.

Other than the obligation of Dixon set forth herein, Dixon disclaims all warranties, express or implied, including but not limited to any implied warranties of merchantability or fitness for a particular purpose, and any other obligation or liability. The foregoing constitutes Dixon's sole obligation with respect to damages, whether direct, incidental or consequential, resulting from the use or performance of the product.

Some products and sizes may be discontinued when stock is depleted, or may require a minimum quantity for ordering.

Dixon®, founded in 1916, is a premier manufacturer and supplier of hose couplings, valves, dry-disconnects, swivels, and other fluid transfer and control products. The company's global reach includes a wide range of products for numerous industries including petroleum exploration, refining, transportation, chemical processing, food & beverage, steel, fire protection, construction, mining and manufacturing. Dixon's strategic objective is to create solutions that make products safer, leak-free, longer lasting, and always available.

dixonvalve.com • Customer Service: 888.226.4673



The Right Connection®

Dixon Specialty Products

225 Talbot Blvd
Chestertown, MD 21620
Customer Service: 888.226.4673
Fx: 410.778.1958